

FM52SU

411927 MASSBLATT / DIMENSION SHEET

Schalthebel für Recht- und Linkslauf
Switch lever for right and left rotation

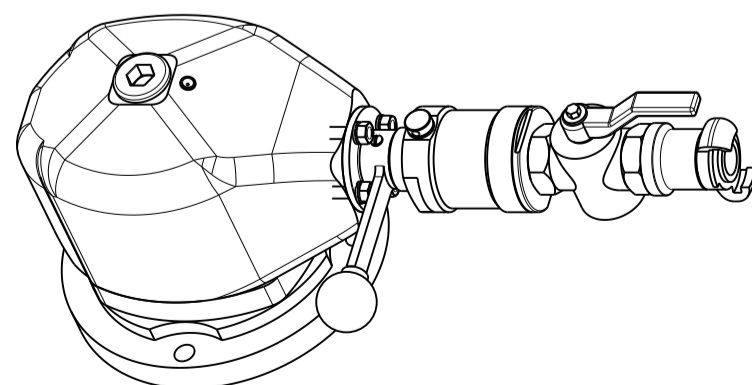
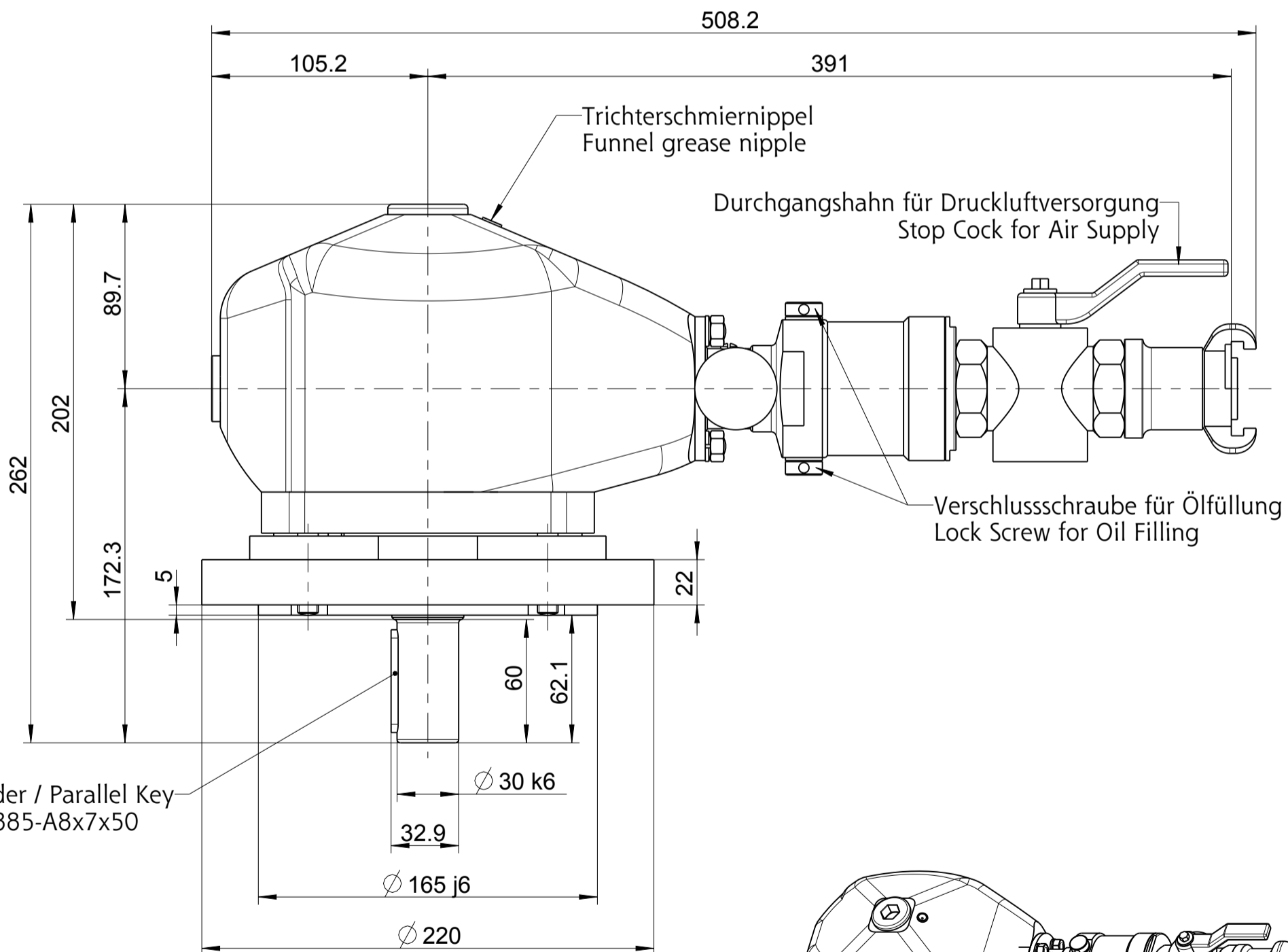
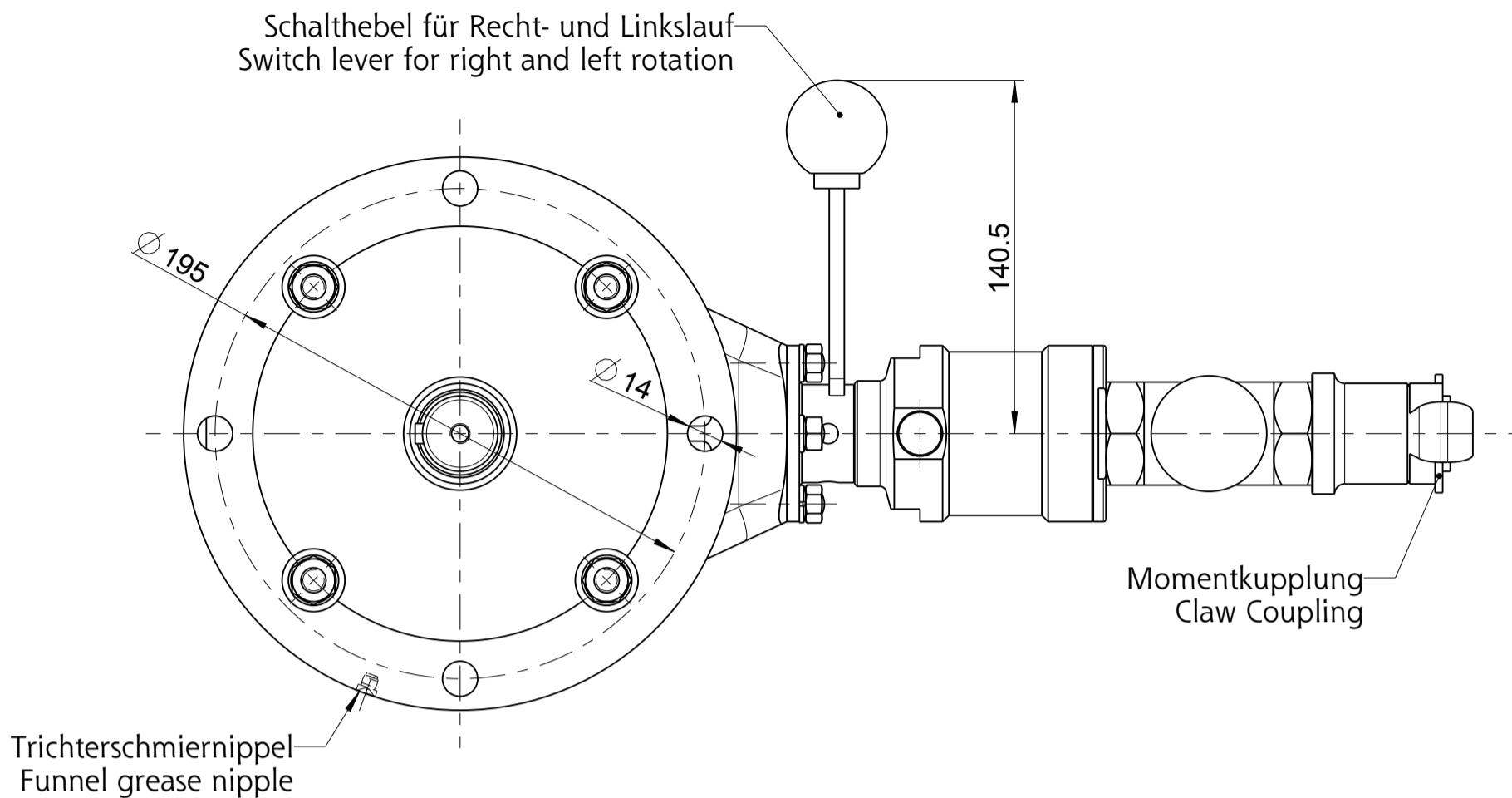

.FM52SU

441741 A

DEPRAG

MASSBLATT

411927

Änderungsstand

1