

MS25PE-W/WS

400890 MAßBLATT / DIMENSION SHEET

Sonderzubehör:
810675 Anschlusskabel 5m
optional equipment:
810675 connection cable 5m

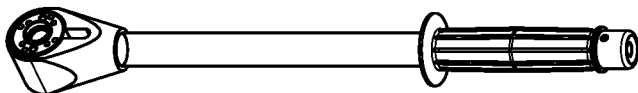
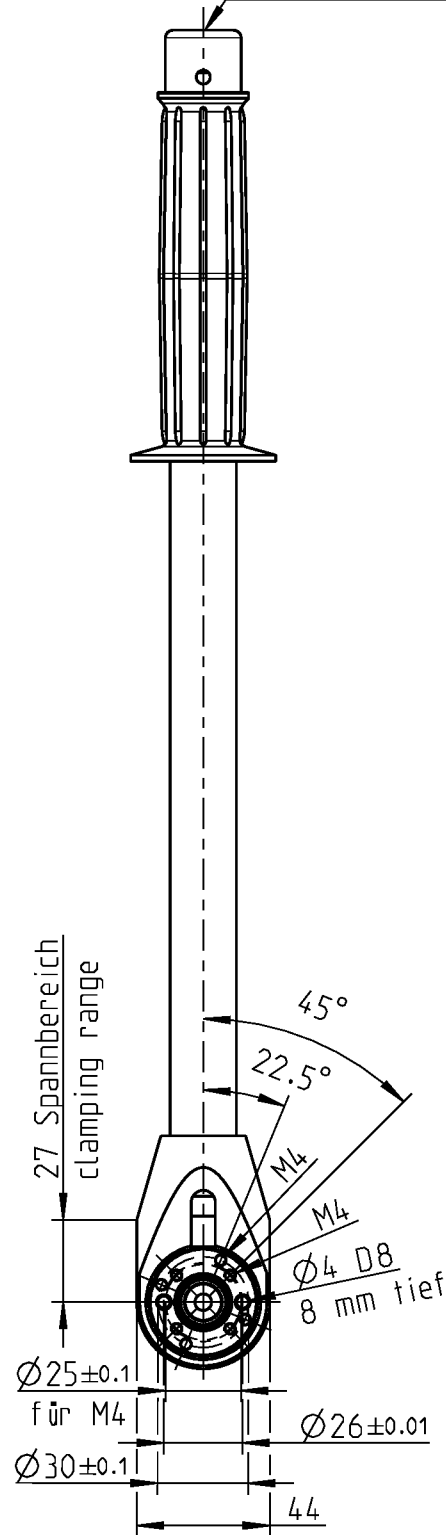
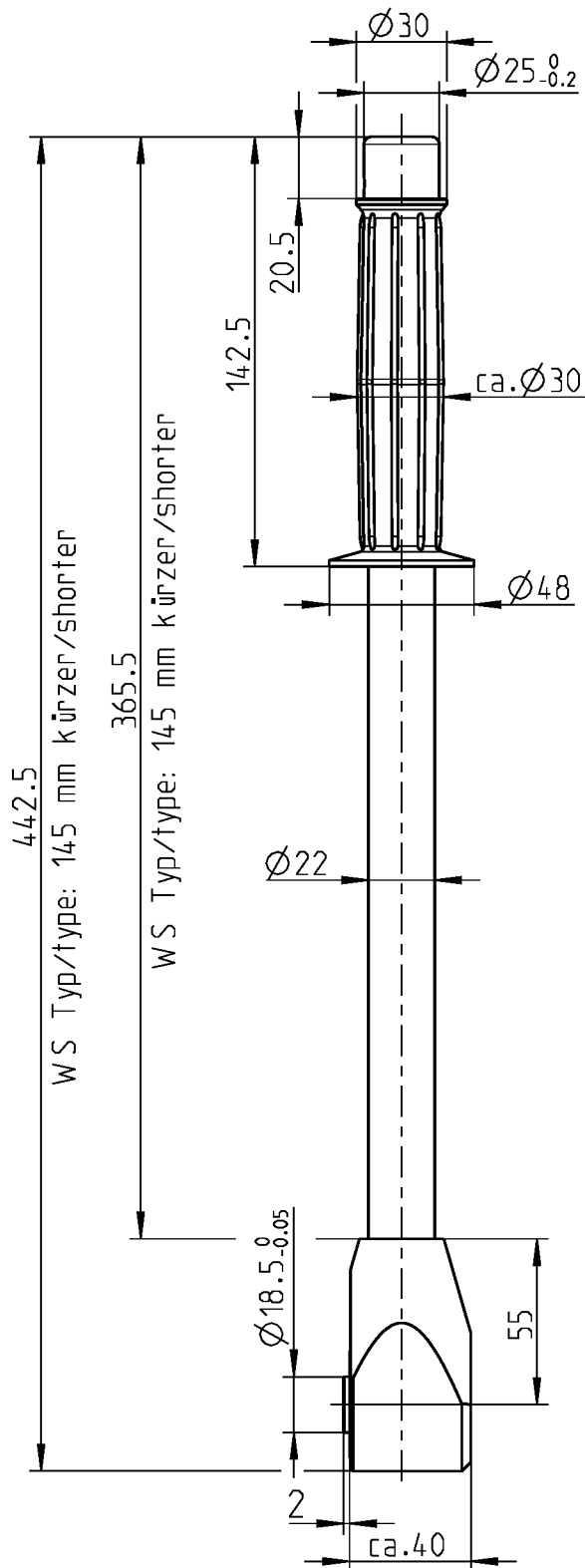

Meßbereich/ measuring range ± 25 Nm

Typ / type

MS25PE-W/WS

DEPRAG

MAßBLATT / DIMENSION SHEET

400890

Änderungsstand

4