

KM32LU

108946 MASSBLATT / DIMENSION SHEET

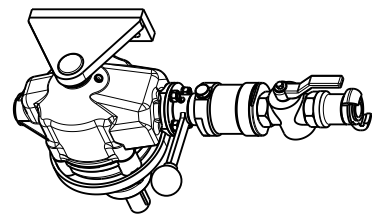
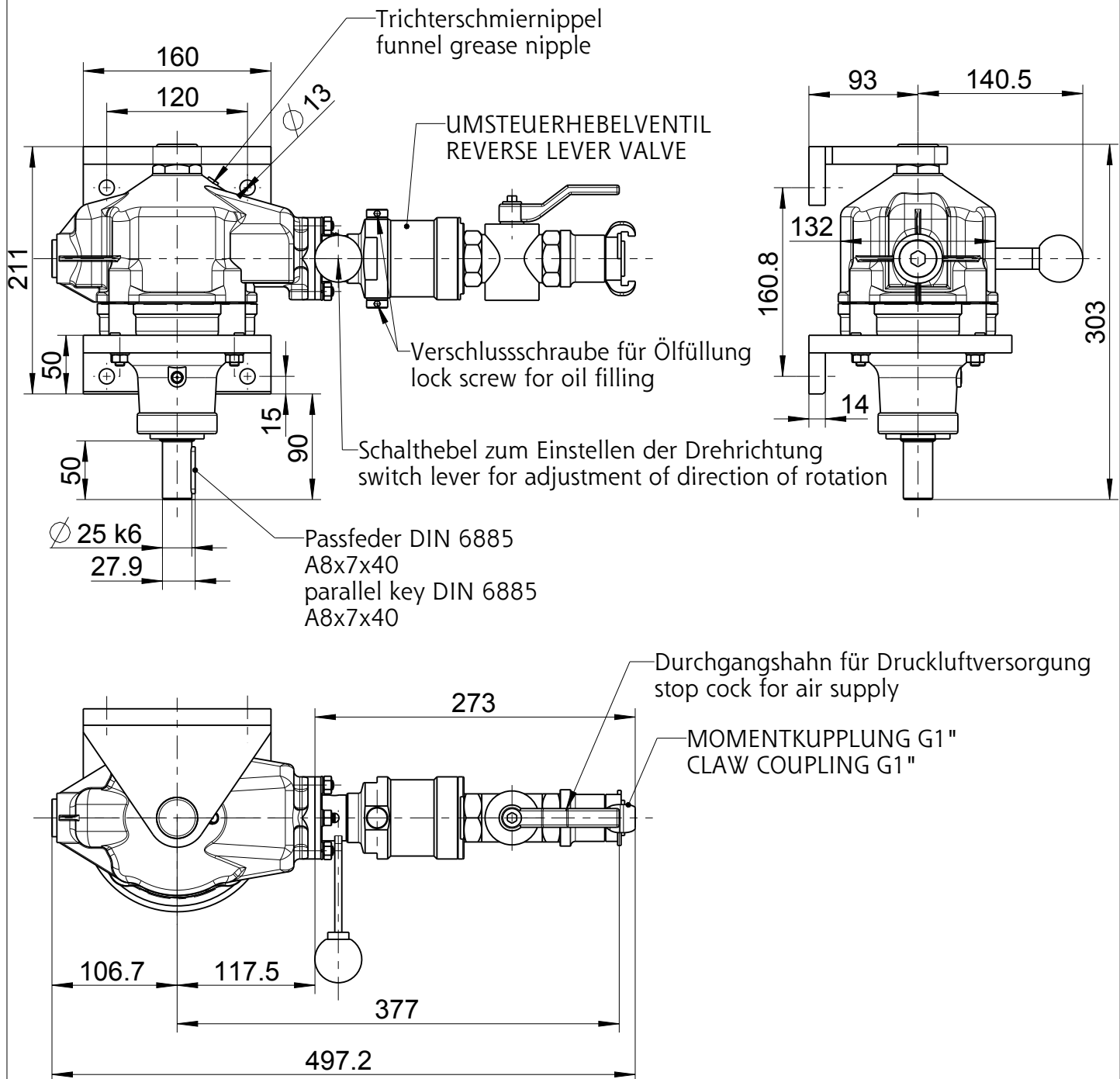

Typ / type
KM32LU

DEPRAG

MASSBLATT / DIMENSION SHEET
108946

drw	1.0
asm	1.1